

*TB 9-5210-207-40

DEPARTMENT OF THE ARMY TECHNICAL BULLETIN

CALIBRATION PROCEDURE FOR MICROMETERS, INSIDE (GENERAL)

Headquarters, Department of the Army, Washington, DC
24 June 2008

Distribution Statement A: Approved for public release; distribution is unlimited.

REPORTING OF ERRORS AND RECOMMENDING IMPROVEMENTS

You can improve this manual. If you find any mistakes or if you know of a way to improve these procedures, please let us know. Mail your letter or DA Form 2028 (Recommended Changes to Publications and Blank Forms) directly to: Commander, U.S. Army Aviation and Missile Command, ATTN: AMSAM-MMC-MA-NP, Redstone Arsenal, AL 35898-5000. A reply will be furnished to you. You may also send in your comments electronically to our E-mail address: 2028@redstone.army.mil or by fax 256-842-6546/DSN 788-6546. For the World Wide Web use: <https://amcom2028.redstone.army.mil>. Instructions for sending an electronic 2028 can be found at the back of this manual.

SECTION		Paragraph	Page
	I. IDENTIFICATION AND DESCRIPTION		
	Test instrument identification	1	2
	Forms, records, and reports.....	2	4
	Calibration description	3	4
	II. EQUIPMENT REQUIREMENTS		
	Equipment required.....	4	4
	Accessories required.....	5	4
	III. CALIBRATION PROCESS		
	Preliminary instructions.....	6	5
	Equipment setup	7	5
	Micrometer head calibration	8	5
	Length calibration.....	9	8
	Final procedure	10	10

*This bulletin supersedes TB 9-5210-207-50, dated 30 March 2004, including all changes.

SECTION I
IDENTIFICATION AND DESCRIPTION

1. Test Instrument Identification. This bulletin provides instructions for the calibration of Micrometers, Inside (General). See figures 1 through 4. Manufacturers' manuals were used as the prime data sources in compiling these instructions. The equipment being calibrated will be referred to as the TI (test instrument) throughout this bulletin.

a. Model Variations. Variations among models are described in text, tables, and figures.

b. Time and Technique. The time required for this calibration is approximately 1 hour, using the physical technique.

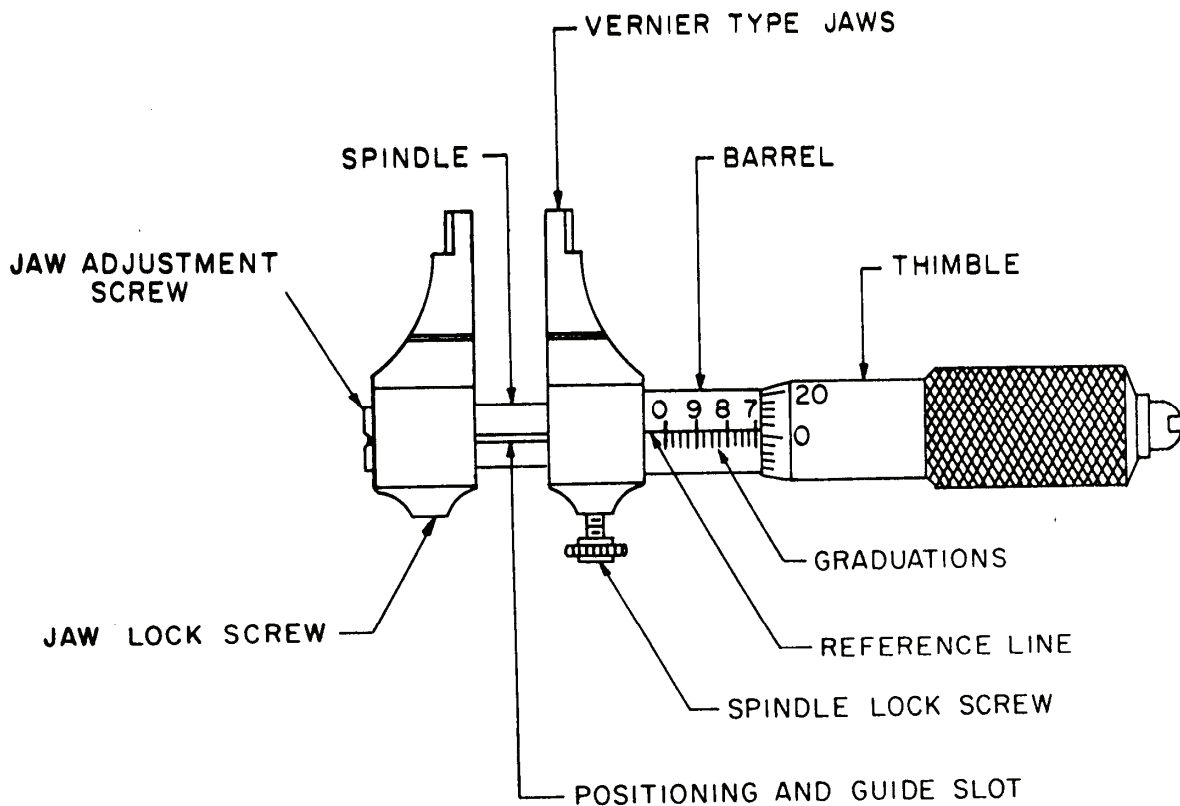

Figure 1. Micrometer, caliper, with jaws.

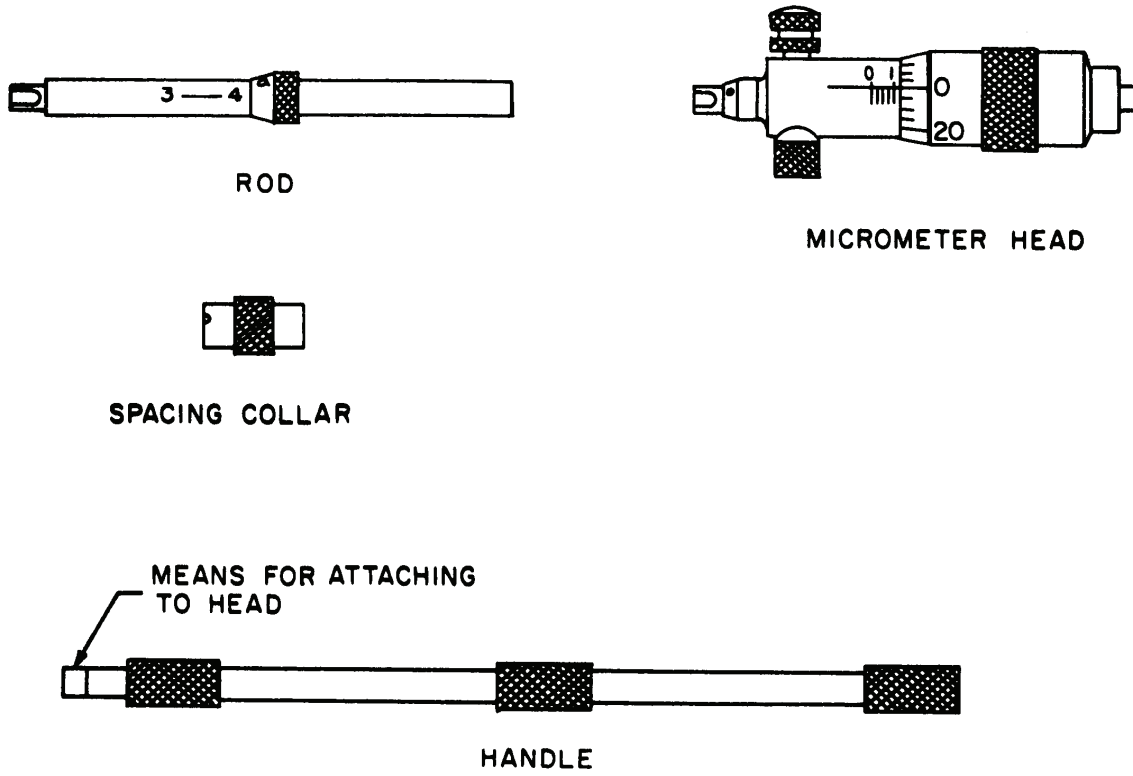

Figure 2. Inside micrometer, rod and sleeve.

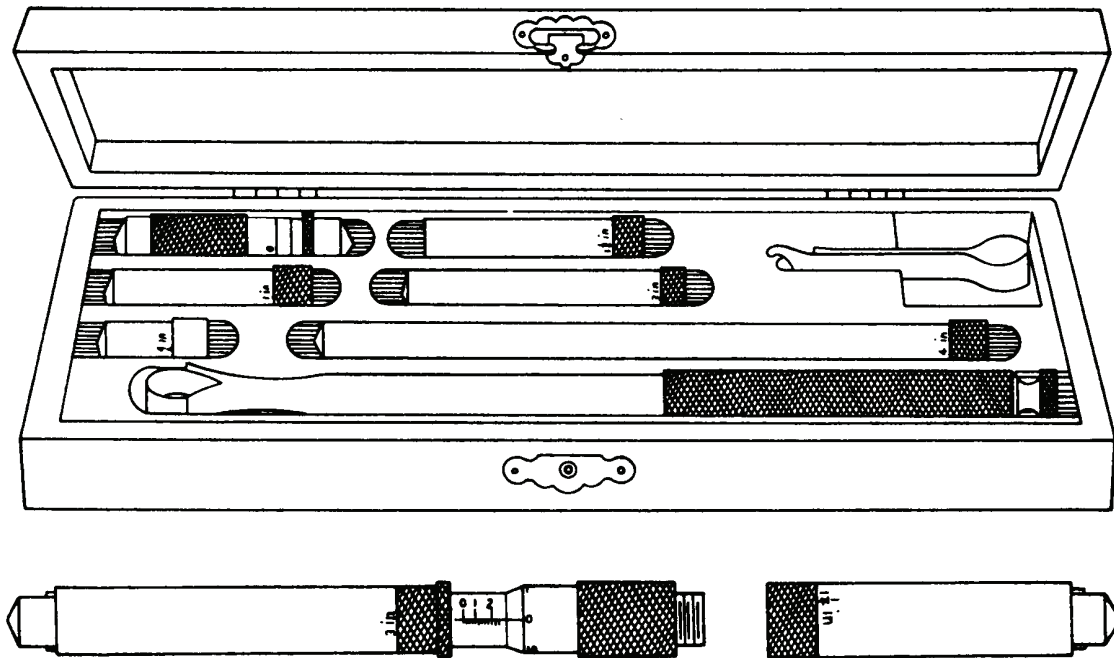

Figure 3. Inside micrometer, tubular, interchangeable.

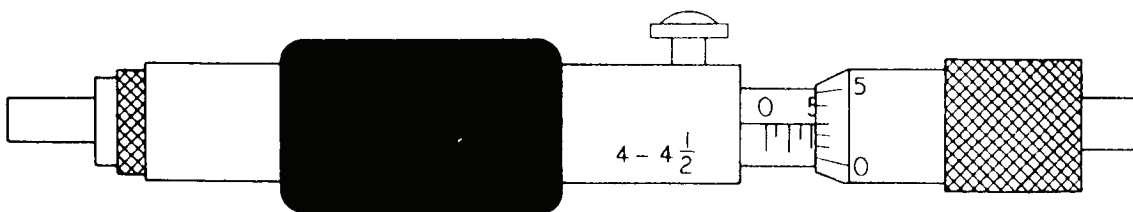

Figure 4. Inside micrometer, tubular, fixed head.

2. Forms, Records, and Reports

a. Forms, records, and reports required for calibration personnel at all levels are prescribed by TB 750-25.

b. Adjustments to be reported are designated (R) at the end of the sentence in which they appear. When adjustments are in tables the (R) follows the designated adjustment. Report only those adjustments made and designated with (R).

3. Calibration Description. TI parameters and performance applications which pertain to this calibration are listed in table 1.

Table 1. Calibration Description

Test instrument parameters	Performance specifications
Length (English)	Range: 1½ to 40 in. Accuracy: ±0.001 in. (without vernier scale) ±0.0001 in. (with vernier scale)
Length (Metric)	Range: 25 to 800 mm Accuracy: ±0.01 mm

SECTION II EQUIPMENT REQUIREMENTS

4. Equipment Required. Table 2 identifies the specific equipment used in this calibration procedure. This equipment is issued with Secondary Reference Calibration Standards Set NSN 4931-00-621-7878. Alternate items may be used by the calibrating activity. The items selected must be verified to perform satisfactorily prior to use and must bear evidence of current calibration. The equipment must meet or exceed the minimum use specifications listed in table 2. The accuracies listed in table 2 provide a four-to-one ratio between the standard and TI. Where the four-to-one ratio cannot be met, the actual accuracy of the equipment selected is shown in parenthesis.

5. Accessories Required. The accessories required for this calibration are common usage accessories, issued as indicated in paragraph 4 above, and are not listed in this calibration procedure.

Table 2. Minimum Specifications of Equipment Required

Common name	Minimum use specifications	Manufacturer and model (part number)
GAGE BLOCK SETS	Range: 1 to 40 in. Accuracy: Grade 3	7901372 7901961

SECTION III CALIBRATION PROCESS

6. Preliminary Instructions

a. The instructions outlined in paragraphs 6 and 7 are preparatory to the calibration process. Personnel should become familiar with the entire bulletin before beginning the calibration.

b. Items of equipment used in this procedure are referenced within the text by common name as listed in table 2.

c. Unless otherwise specified, verify the result of each test and, whenever the test requirement is not met, take corrective action before continuing with the calibration. Adjustments required to calibrate the TI are included in this procedure. Additional maintenance information is contained in the manufacturers' manuals for this TI.

7. Equipment Setup

a. Prepare a clean work area and allow equipment and TI to stabilize at room temperature for 1 hour.

b. Observe that the TI is free of nicks and burrs.

c. Gently push and pull the TI micrometer head laterally to insure that there is no excessive backlash in the threads. If backlash is indicated, refer to paragraph 8 b below.

8. Micrometer Head Calibration

a. Performance Check

(1) Select the appropriate gage blocks required to verify the range of the TI from gage block set.

(2) Assemble the gage blocks as shown in figure 5. Each stack of gage blocks must have an inside caliper jaw at each end of the gage blocks to serve as end stops for the TI. The gage blocks and end stops must be firmly wrung together and secured with the tie rods supplied with the gage block set.

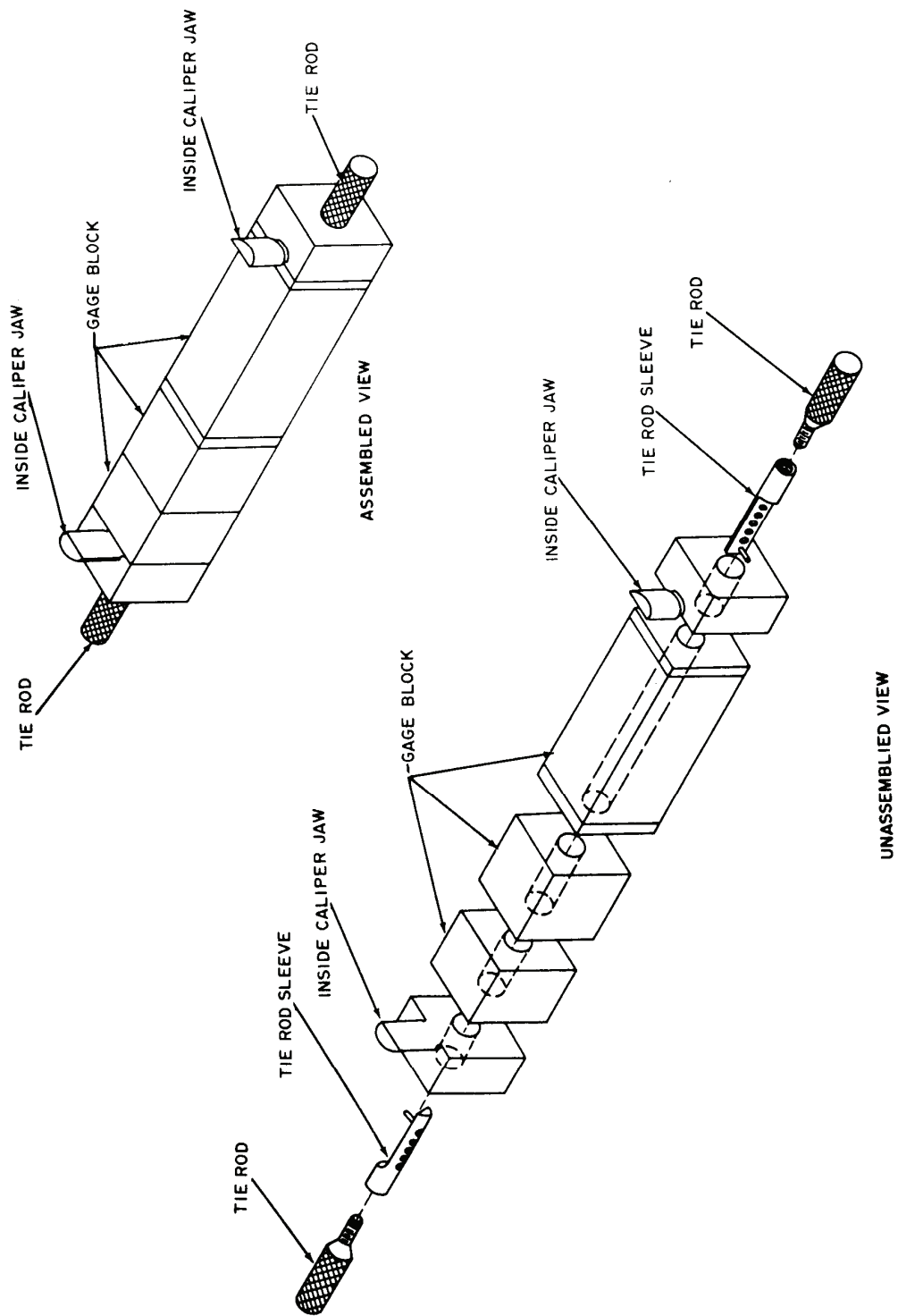

Figure 5. Gage block assembly.

NOTE

Before a TI graduated in metric units can be calibrated, the metric units must first be converted to inches. The formula is 1 inch = 25.4 millimeters, and 1 millimeter = 0.03937 inch.

- (3) Set up the TI to be calibrated as shown in figure 6.

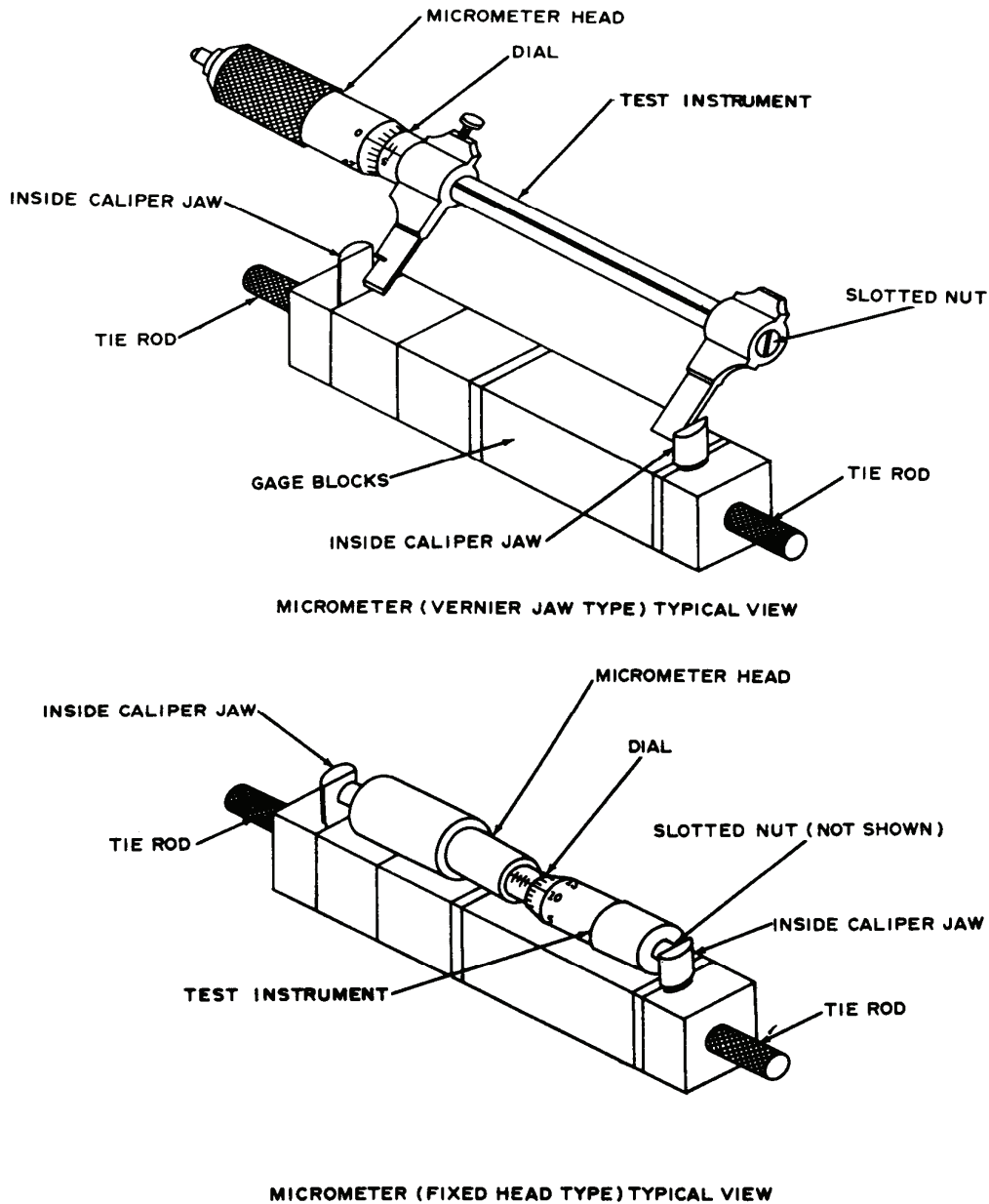

Figure 6. Micrometer head calibration.

- (4) Using the dimensions listed in table 3, verify the TI micrometer head at each checkpoint. If the TI does not indicate zero (0) ± 0.0002 in. (or zero ± 0.0005 in. for TI's without vernier), perform **b** below.

Table 3. Gage Block Stacks

	Micrometer head checkpoint (in.)	Equivalent gage block stacks between end stops (in.)
1/2 in. micrometer head movement	0	1.500
	0.250	1.750
	0.500	2.000
1 in. micrometer head movement	0	2.000
	0.500	2.500
	1.000	3.000

b. Adjustments

(1) Tighten slotted nut on TI to remove any backlash.

(2) Zero set TI micrometer head at its minimum size in accordance with the manufacturer's instructions.

9. Length Calibration

a. Performance Check

(1) Verify each extension rod and/or caps in combination with micrometer head, using the techniques in paragraph 8 a (1) through (3) above. Verify only the minimum indication for each combination.

(2) The gage block dimensions used to verify each setup must be equal to the minimum length of the extension rod, micrometer head, and end-cap combination (size marked on each extension rod) to be verified.

(3) The permissible error in length will not exceed the applicable tolerances specified in tables 4 through 10.

Table 4. Inside Micrometer, Caliper, with Jaws, (English Measure) Permissible Error - Inches

Size	Range	Length (±)	
		0.001 Graduations	0.0001 Graduations
1	0.200 to 1	0.0005	0.0002
1 1/2	0.500 to 11 1/2	0.0005	0.0002
2	1 to 2	0.0005	0.0002

Table 5. Inside Micrometer, Rod and Sleeve (English Measure) Permissible Error - Inches

Range	Length (±)	
	0.001 Graduations	0.0001 Graduations
1 to 2	0.0005	0.0003
2 to 8	0.0005	0.0004
2 to 12	0.0005	0.0005
8 to 32	0.001	0.001
8 to 36	0.001	0.001

Table 6. Inside Micrometer, Rod and Sleeve (Metric Measure) Permissible Error - Millimeters

Range	Length (±)
25 to 50	0.0075
50 to 200	0.010
50 to 300	0.0125
200 to 800 or 900	0.025

Table 7. Inside Micrometer, Tubular, Interchangeable Head (English Measure) Permissible Error - Inches

Range	Movement of head	Length (±)	
		0.001 Graduations	0.0001 Graduations
1½ to 8	½	0.0005	0.0005
1½ to 12	½	0.0005	0.0005
4 to 24	1	0.001	0.0007
4 to 32	1	0.001	0.0009
4 to 40	1	0.001	0.001
1½ to 32 (two heads)	½ and 1	0.001	0.0015

Table 8. Inside Micrometer, Tubular, Interchangeable Head (Metric Measure) Permissible Error - Millimeters

Range	Movement of head	Length (±)
40 to 200	13	0.012
40 to 300	13	0.012
100 to 600	25	0.018
100 to 800	25	0.022
100 to 1000	25	0.022
40 to 800 (two heads)	13 and 25	0.035

Table 9. Inside Micrometer, Tubular, Fixed Head (English Measure) Permissible Error - Inches

Range	Movement of head	Length (±)	
		0.001 Graduations	0.0001 Graduations
2 to 2½	½	0.0005	0.0003
2½ to 3	½	0.0005	0.0003
3 to 3½	½	0.0005	0.0003
3½ to 4	½	0.0005	0.0003
4 to 4½	½	0.0005	0.0003
4½ to 5	½	0.0005	0.0003
5 to 12 (in inch increments)	½	0.0005	0.0003

Table 10. Inside Micrometer, Tubular, Fixed Head (Metric Measure) Permissible Error - Millimeters

Range	Movement of head	Length (±)
50 to 63	13	0.007
63 to 75	13	0.007
75 to 88	13	0.007
88 to 100	13	0.007
100 to 113	13	0.007
113 to 125	13	0.007
125 to 300 (in 25mm increments)	25	0.010

b. Adjustments. Adjust contact points on each extension rod as required, for zero indication, when fit is the same as when zero setting micrometer head.

10. Final Procedure

- a.** At the option of the calibrating laboratory, individual items within a set may be oiled to prevent rust and sealed in polyethylene film. Upon recalibration, those items with unbroken seals and no evidence of damage may remain sealed until used.
- b.** Annotate and affix DA label/form in accordance with TB 750-25.

By Order of the Secretary of the Army:

Official:

GEORGE W. CASEY, JR.
General, United States Army
Chief of Staff



JOYCE E. MORROW
Administrative Assistant to the
Secretary of the Army

0812106

Distribution:

To be distributed in accordance with STD IDS No. RLC-1500, 2 January 2003, requirements for calibration procedure TB 9-5210-207-40.

Instructions for Submitting an Electronic 2028

The following format must be used if submitting an electronic 2028. The subject line must be exactly the same and all fields must be included; however, only the following fields are mandatory: 1, 3, 4, 5, 6, 7, 8, 9, 10, 13, 15, 16, 17, and 27.

From: "Whomever" whomever@redstone.army.mil
To: <2028@redstone.army.mil

Subject: DA Form 2028

1. **From:** Joe Smith
2. **Unit:** home
3. **Address:** 4300 Park
4. **City:** Hometown
5. **St:** MO
6. **Zip:** 77777
7. **Date Sent:** 19-OCT-93
8. **Pub no:** 55-2840-229-23
9. **Pub Title:** TM
10. **Publication Date:** 04-JUL-85
11. **Change Number:** 7
12. **Submitter Rank:** MSG
13. **Submitter FName:** Joe
14. **Submitter MName:** T
15. **Submitter LName:** Smith
16. **Submitter Phone:** 123-123-1234
17. **Problem:** 1
18. **Page:** 2
19. **Paragraph:** 3
20. **Line:** 4
21. **NSN:** 5
22. **Reference:** 6
23. **Figure:** 7
24. **Table:** 8
25. **Item:** 9
26. **Total:** 123
27. **Text**

This is the text for the problem below line 27.

